



AS5610-52X
48-Port 10G
Top-of-Rack Switch

Installation Guide

Installation Guide

AS5610-52X 48-Port 10G Top-of-Rack Switch

with 48 10GBASE SFP+ Ports,
4 40GBASE QSFP+ Ports,
1 1000BASE-T (RJ-45) Management Port,
2 Power Supply Units (F2B and B2F Airflow),
and 1 Fan Tray Module (F2B and B2F Airflow)

How to Use This Guide

This guide includes detailed information on the switch hardware, including network ports, power, cabling requirements, as well as plug-in modules and transceivers. This guide also provides general installation guidelines and recommended procedures. To deploy this switch effectively and ensure trouble-free operation, you should first read the relevant sections in this guide so that you are familiar with all its hardware components.

Who Should Read This Guide? This guide is for network administrators and support personnel that install, operate, and maintain network equipment. The guide assumes a basic working knowledge of LANs (Local Area Networks) and can be read by those that are new to network equipment, or those with more experience.

How This Guide is Organized The organization of this guide is based on the switch's main hardware components. Each chapter includes information about a specific component with relevant specifications and installation procedures. A switch overview section is also provided.

For Users New to Switches — If you are new to network switches, it is recommended that you first read all chapters in this guide before installing the switch.

For Experienced Users — If you are already familiar with installing and operating network switches, the Switch Description and Installation Overview chapters provide you with enough information to install the switch. Other chapters can be left for reference, when needed.

The guide includes these chapters:

- ◆ [Chapter 1 - Switch Description](#) — Includes a switch overview, key component identification, key technical specifications, and switch deployment information.
- ◆ [Chapter 2 - Installation Overview](#) — Includes details of the package contents and an outline of switch installation tasks.
- ◆ [Chapter 3 - Switch Chassis](#) — Includes switch chassis rack installation, and system cooling requirements.
- ◆ [Chapter 4 - Power and Grounding](#) — Includes installation of AC power modules, switch grounding, and powering on the switch.

- ◆ [Chapter 5 - Port Connections](#) — Includes information on network interfaces, installing optional transceivers, and cabling specifications.
- ◆ [Chapter 6 - Switch Management](#) — Connecting to the switch for management, and information on the system status LEDs.
- ◆ [Appendix A - Troubleshooting](#) — Information for troubleshooting switch installation and operation.

Related Documentation

This guide focuses on switch hardware and installation, it does not cover software configuration of the switch. For specific information on how to operate and use the management functions of the switch, see the following guides:

*CLI Command Reference
Administrator's Guide*

For all safety information and regulatory statements, see the following document:

*Quick Start Guide
Safety and Regulatory Information*

Conventions The following conventions are used throughout this guide to show information:



Note: Emphasizes important information or calls your attention to related features or instructions.



Caution: Alerts you to a potential hazard that could cause loss of data, or damage the system or equipment.



Warning: Alerts you to a potential hazard that could cause personal injury.

Revision History This section summarizes the changes in each revision of this guide.

December 2013 Revision

This is the first revision of this guide.

Contents

How to Use This Guide	3
Contents	5
Figures	7
Tables	9
1 Switch Description	10
Overview	10
Key Hardware Components	11
Key Technical Specifications	13
Data Center Deployment	14
Rack Cooling	15
2 Installation Overview	18
Package Contents	18
Switch Installation Tasks	19
3 Switch Chassis	25
General Installation Guidelines	25
How to Install the Switch in a Rack	26
Rack-Mounting Items	26
Rack-Mount Procedure	26
Switch Cooling Requirements	28
Rack Cooling	29
Fan Tray Module	29
How to Replace a Fan Tray	30
4 Power and Grounding	31
Power Supply Modules	31
Grounding the Chassis	33
How to Connect to AC Power	34

5	Port Connections	37
	Cable Labeling and Connection Records	38
	Understanding the Port Status LEDs	39
	How to Install an SFP/SFP+/QSFP+ Transceiver	40
	How to Connect to Twisted-Pair Copper Ports	41
	Copper Cabling Guidelines	42
	10/100BASE-TX Pin Assignments	42
	1000BASE-T Pin Assignments	43
	Connection Procedure	43
	How to Connect to SFP/SFP+ Fiber Optic Ports	44
	Connection Procedure	44
	How to Connect to QSFP+ Fiber Optic Ports	46
	Connection Procedure	46
	DAC Connections	48
	Making DAC Connections	48
6	Switch Management	51
	Understanding the System Status LEDs	52
	How to Connect to the Management Port	53
	How to Connect to the Console Port	54
	How to Connect to the USB Port	56
	How to Reset the Switch	57
A	Troubleshooting	58
	Diagnosing LED Indicators	58
	System Self-Diagnostic Test Failure	58
	Power and Cooling Problems	59
	Installation	59
	In-Band Access	59
	Index	60

Figures

Figure 1: Front Panel	11
Figure 2: Rear Panel	12
Figure 3: Cloud Data Center Deployment	14
Figure 4: Converged Ethernet Data Center Deployment	15
Figure 5: F2B Airflow Cooling	15
Figure 6: B2F Airflow Cooling	16
Figure 7: Installing the Switch in a Rack	19
Figure 8: Grounding the Switch	20
Figure 9: Connecting AC Power	21
Figure 10: System LEDs	21
Figure 11: Console Port	22
Figure 12: Making a Connection to a QSFP+ Transceiver	23
Figure 13: Attaching the Brackets	27
Figure 14: Installing the Switch in a Rack	27
Figure 15: Switch Cooling	28
Figure 16: Fan Tray	30
Figure 17: AC Power Supply Module	32
Figure 18: Power Supply Module LED	32
Figure 19: Grounding Terminal	33
Figure 20: AC PSU and Power Socket	34
Figure 21: Port Status LEDs	39
Figure 22: Port Status LEDs	39
Figure 23: Inserting an SFP/SFP+/QSFP+ Transceiver into a Slot	41
Figure 24: RJ-45 Connector	42
Figure 25: Making Connections to an SFP+ Transceiver	45
Figure 26: Connecting to a QSFP+ Transceiver	47
Figure 27: Making DAC Connections	49
Figure 28: System LEDs	52
Figure 29: Management Port	53

Figures

Figure 30: Console Port	54
Figure 31: Console Port Connection	55
Figure 32: USB Port	56
Figure 33: Reset Button	57

Tables

Table 1: Key Technical Specifications	13
Table 2: Fan Tray Specifications	30
Table 3: AC Power Supply Module Specifications	32
Table 4: Maximum Twisted-Pair Copper Cable Lengths	41
Table 5: 10/100BASE-TX MDI and MDI-X Port Pinouts	42
Table 6: 1000BASE-T MDI and MDI-X Port Pinouts	43
Table 7: Maximum 10 Gigabit Ethernet Fiber Cable Lengths	44
Table 8: Maximum Gigabit Ethernet Fiber Cable Lengths	44
Table 9: Maximum 40 Gigabit Ethernet Fiber Cable Lengths	46
Table 10: Maximum 10GBASE-CR 10 Gigabit Ethernet Cable Lengths	48
Table 11: Maximum 40GBASE-CR4 40 Gigabit Ethernet Cable Lengths	48
Table 12: System Status LEDs	52
Table 13: RJ-45 Management Port Status LEDs	53
Table 14: Console Cable Wiring	55
Table 15: Troubleshooting Chart	58

1

Switch Description

This chapter includes these sections:

- ◆ [“Overview” on page 10](#)
- ◆ [“Key Technical Specifications” on page 13](#)
- ◆ [“Data Center Deployment” on page 14](#)

Overview

Thank you for choosing the AS5610-52X switch system. This switch is built with leading-edge technology to deliver reliable high-performance connectivity for your data network.

The AS5610-52X switch is a high-performance top-of-rack switch, designed for data center operating environments. The switch provides 48 10G Ethernet Small Form Factor Pluggable Plus (SFP+) transceiver slots, four 40G Quad-SFP+ (QSFP+) ports, and two 1G RJ-45 ports. The switch also includes replaceable dual power supply units and a fan tray module.

The switch supports a full set of Layer 2 switching, data center bridging, and Layer 3 routing features. The switch can be deployed as a top-of-rack (TOR) or distributed spine switch to form a network fabric that can reduce infrastructure expenses and power consumption in the data center. This network fabric can be used to interconnect tens of thousands of servers delivering cloud computing services.

The switch also offers an option of front-to-back (F2B) or back-to-front (B2F) airflow cooling for rack deployment with either blade servers or other switches, allowing cool aisles to be maintained without creating “hot loops.”

Key Hardware Components The AS5610-52X switch consists of several key hardware components. This manual describes each specific component, or related components, together with their installation requirements and procedures in each chapter. To understand each component in detail, refer to the relevant section.

Figure 1: Front Panel

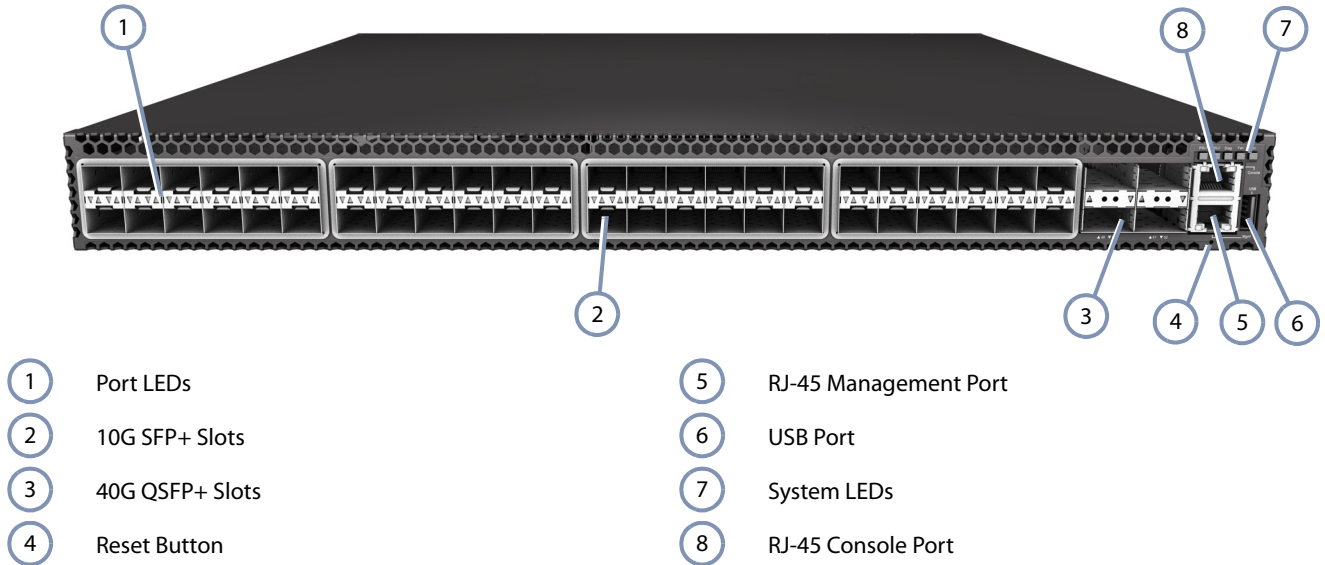

10G SFP+ Slots

The switch contains 48 Small Form Factor Pluggable Plus (SFP+) transceiver slots that support 10G Ethernet SFP+ transceivers, or 1G Ethernet SFP transceivers. For more information, see [“How to Connect to SFP/SFP+ Fiber Optic Ports” on page 44.](#)

40G QSFP+ Slots

The switch contains four Quad Small Form Factor Pluggable Plus (QSFP+) transceiver slots that operate up to 40 Gbps full duplex. For more information, see [“How to Connect to QSFP+ Fiber Optic Ports” on page 46.](#)

Management Port

The RJ-45 port labeled “Management” provides a dedicated 1000BASE-T management interface. For more information, see [“How to Connect to the Management Port” on page 53.](#)

Console Port

The RJ-45 port labeled “Console” provides an out-of-band serial connection to a terminal or a PC running terminal emulation software. The port can be used for performing switch monitoring and configuration. For more information, see [“How to Connect to the Console Port” on page 54.](#)

USB Port

A USB port is provided on the switch front panel. This port is for transferring configuration files from a USB storage device to the switch's flash memory. For more information, see ["How to Connect to the USB Port"](#) on page 56.

Reset Button

Pressing the reset button on the front panel causes the switch to perform a hard reset. For more information, see ["How to Reset the Switch"](#) on page 57.

System LEDs

For information on system status LED indicators, see ["Understanding the System Status LEDs"](#) on page 52.

Port LEDs

For information on port status LED indicators, see ["Understanding the Port Status LEDs"](#) on page 39.

Figure 2: Rear Panel

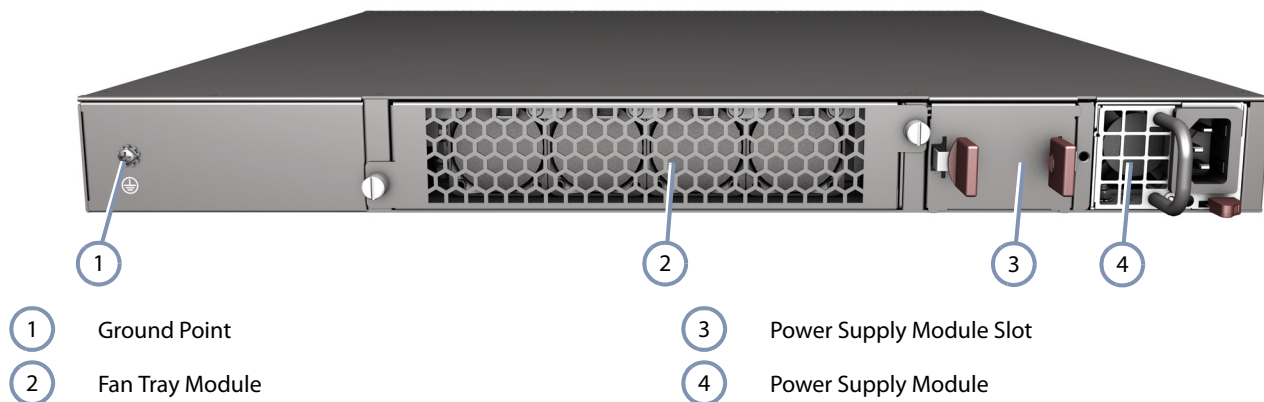

Grounding Terminal

The grounding terminal must be connected to a ground source that provides local earth potential. For more information, see ["Grounding the Chassis"](#) on page 33.

Power Supply Modules

The switch supports dual hot-swappable AC power supply units (PSUs). You can install up to two PSUs with matching airflow direction in the switch. For more information on the switch power supplies, how to install them, and how to power-on the switch, see ["Power Supply Modules"](#) on page 31.

Fan Tray Module

The fan tray module provides air cooling for the switch system. For more information, see ["Switch Cooling Requirements"](#) on page 28.

Key Technical Specifications

The following table contains key system specifications for the switch.

Table 1: Key Technical Specifications

Item	Specification
Ports	48 10 Gbps SFP+ transceiver slots 4 40 Gbps QSFP+ transceiver slots 1 10/100/1000 Mbps RJ-45 Management port
Network Interface	Ports 1~48: SFP+ <ul style="list-style-type: none"> ◆ 10 Gbps SFP+ transceivers: 10GBASE-CR, 10GBASE-SR ◆ 1 Gbps SFP transceivers: 1000BASE-SX, 1000BASE-LX Ports 49~52: QSFP+ <ul style="list-style-type: none"> ◆ 40 Gbps QSFP+ transceivers: 40GBASE-CR4, 40GBASE-SR4 Management Port <ul style="list-style-type: none"> ◆ 10/100/1000BASE-T, RJ-45 connector
Buffer Architecture	32 Mbit packet buffer
Aggregate Bandwidth	1280 Gbps
Switching Database	128K MAC address entries
LEDs	System: PS1, PS2, Diag (Diagnostic), Fan, Loc (Locator) Ports 1~52: Status (link and activity)
Power Supply Module	100-240 VAC, 50-60 Hz, auto-sensing; hot pluggable 400 Watts@ 240V/100V per module
Power Consumption	165 Watts maximum
Weight	8.395 kg (18.51 lb), with two installed power supply modules
Size	W x D x H: 438.4 x 473 x 43.4 mm (17.26 x 18.62 x 1.71 inches)
Temperature	Operating: 0 °C to 40 °C (32 °F to 104 °F) Storage: -40 °C to 70 °C (-40 °F to 158 °F)
Humidity	Operating: 5% to 95% (non-condensing)
Out-of-Band Management	RS-232 RJ-45 console port
In-Band Management	SSH, Telnet, SNMP, or HTTP
Software Loading	HTTP, FTP/TFTP in-band
Forwarding Mode	Store-and-forward
Throughput	Wire speed
Flow Control	Full Duplex: IEEE 802.3x Half Duplex: Back pressure

Data Center Deployment

The switch is designed for high-availability data center environments with a high port density. The switch includes redundant, hot-swappable, load-sharing AC PSUs, a hot-swappable fan tray, and port-to-power and power-to-port airflow direction options. Meeting the network scaling requirements of enterprise and cloud data centers, the switch can be deployed as a top-of-rack switch or as part of a distributed spine network, providing full line-rate switching at Layer 2 or Layer 3 across all ports.

Figure 3: Cloud Data Center Deployment

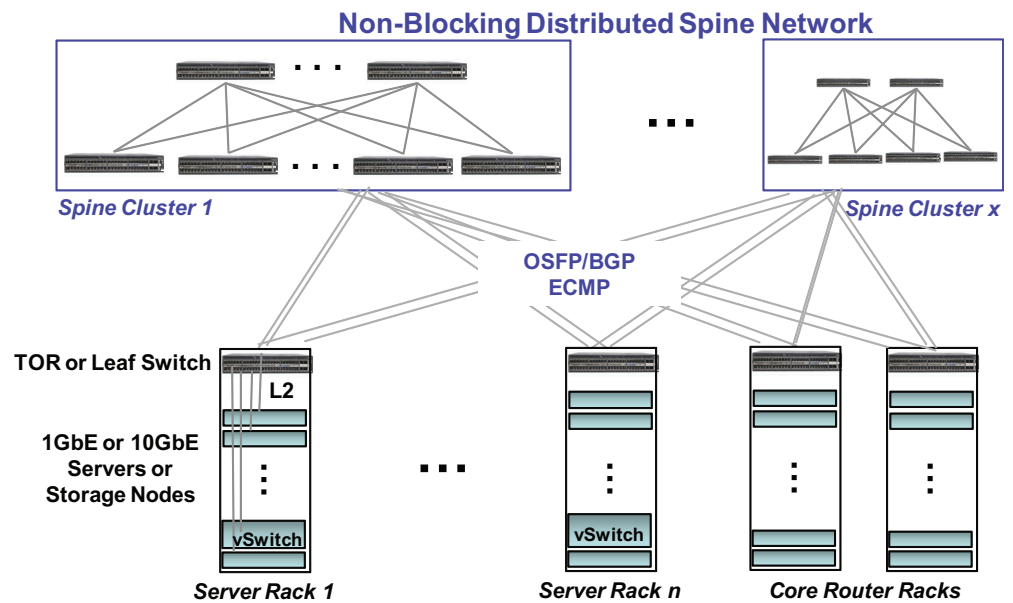

In many data center configurations, Ethernet connections link servers and data networks, and Fibre Channel connections link servers to storage networks. This switch enables the creation of a converged network, which employs lossless Ethernet connections between FCOE storage, servers, and other data network switches.

Figure 4: Converged Ethernet Data Center Deployment

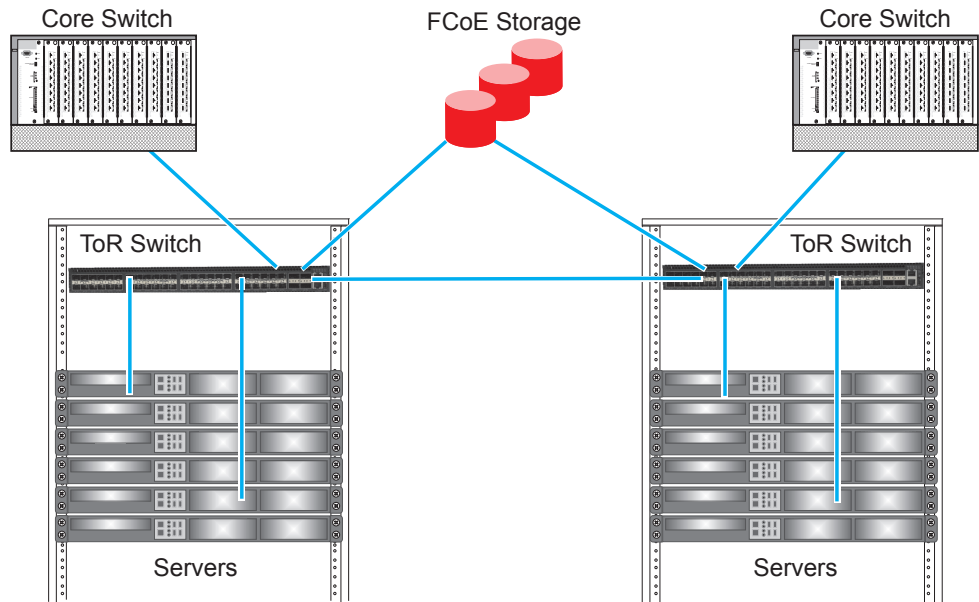

Rack Cooling The top-of-rack switch is a high-performance, high-density unit that generates a substantial amount of heat. When mounted in a rack with other equipment, it is important that the switch has the same airflow direction to avoid “hot loops” in the data center aisles. Hot loops increase cooling requirements since warm air is drawn into rack devices instead of cool air.

Most rack-mounted blade servers draw cool air from the front and expel hot air at the rear. The top-of-rack switch includes power supply units and a fan tray module that have a front-to-back (F2B) airflow direction that maintains cool aisles in the data center.

Figure 5: F2B Airflow Cooling

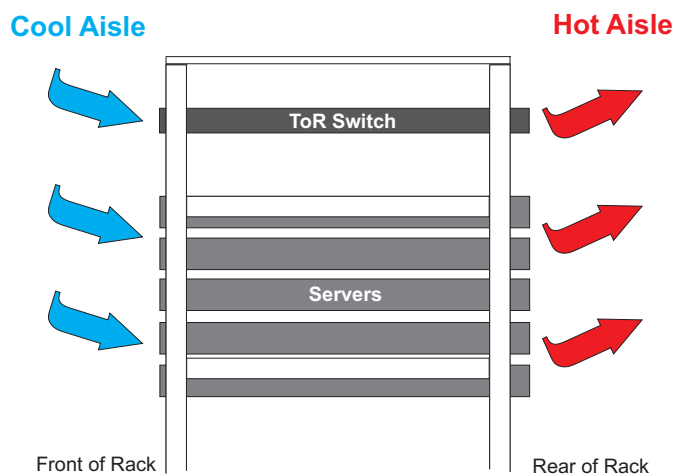

When mounted in a rack with other network equipment that may have a back-to-front (B2F) airflow direction, the top-of-rack switch includes power supply and fan tray modules that reverse the airflow direction through the switch. This enables various deployment options for the switch in the data center.

Figure 6: B2F Airflow Cooling

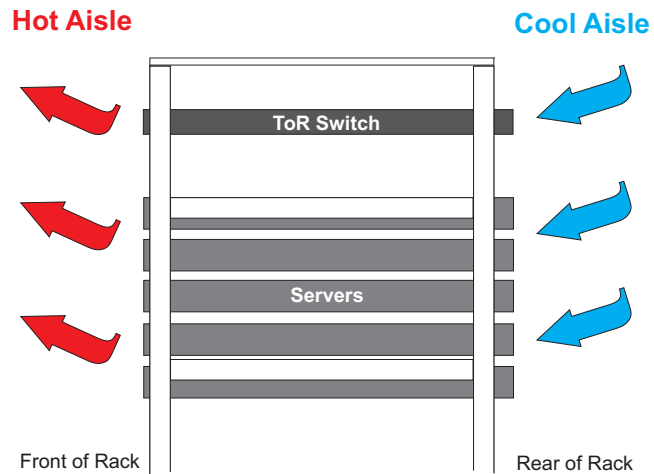

2

Installation Overview

This chapter includes these sections:

- ◆ [“Package Contents” on page 18](#)
- ◆ [“Switch Installation Tasks” on page 19](#)

Package Contents

After unpacking the switch, check the contents to be sure you have received all the components.

- ◆ AS5610-52X 10G Top-of-Rack Switch
- ◆ Rack Mounting Kit containing two brackets and eight screws for attaching the brackets to the switch
- ◆ Grounding wire
- ◆ Power cord—either Japan, US, Continental Europe or UK
- ◆ Console cable (RJ-45 to DB-9)
- ◆ Quick Start Guide
- ◆ Safety and Regulatory Information

Switch Installation Tasks

Follow these tasks to install the switch in your network. For full details on each task, go to the relevant chapter or section by clicking on the link.



Caution: Before installing your switch, first review all the safety statements and guidelines in the *Safety and Regulatory Information* document.

Task 1 **Unpack package and check contents**

Unpack your switch and check the package contents to be sure you have received all the items. See [“Package Contents”](#) on page 18.

Task 2 **Install the Chassis**

The switch is designed to be installed in a standard 19-inch equipment rack. Plan your rack installation and install the switch chassis in the rack. Be sure to take into account switch cooling requirements.

➔ Go to the chapter [“Switch Chassis”](#)

Figure 7: Installing the Switch in a Rack

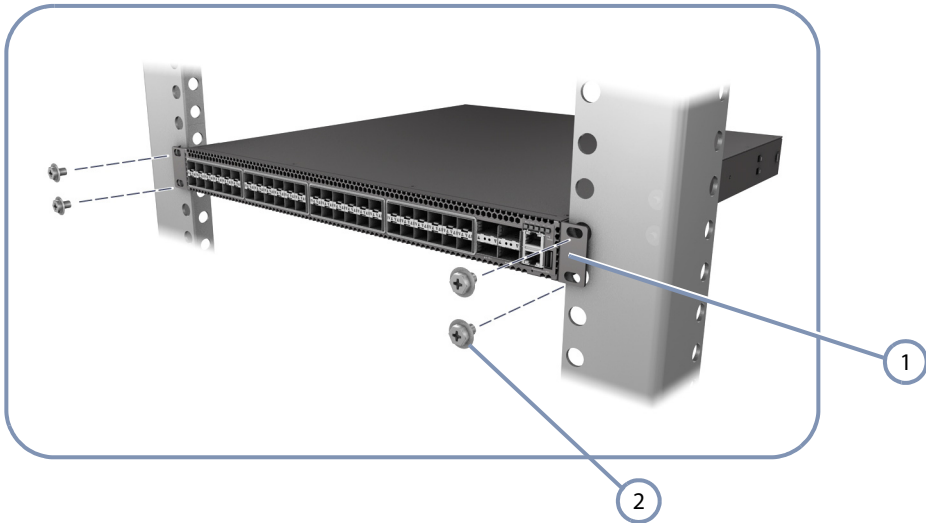

① Attach the brackets to the switch,

② Use the rack mounting screws supplied with the rack to secure the switch in the rack.

Task 3 Ground the Switch

Before powering on the switch, ground the switch to earth.

Ensure the rack on which the switch is to be mounted is properly grounded and in compliance with ETSI ETS 300 253. Verify that there is a good electrical connection to the grounding point on the rack (no paint or isolating surface treatment.).



Caution: The earth connection must not be removed unless all supply connections have been disconnected.

Figure 8: Grounding the Switch

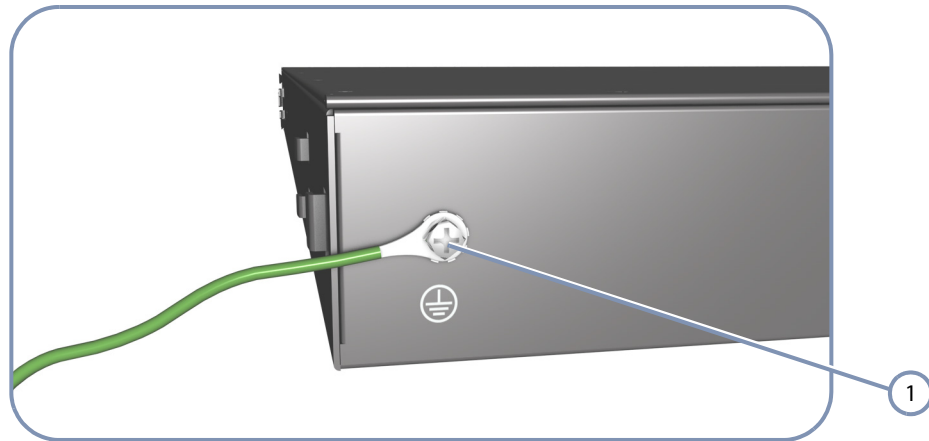

- 1 Attach the included grounding wire to the grounding terminal on the switch rear panel, then to rack ground.

Task 4 Install Power Modules and Power On

Install power modules, then power on. The switch supports up to two PSUs that have a matching airflow direction as the installed fan tray.



Caution: The switch includes plug-in power supply and fan tray modules that are installed into its chassis. All installed modules must have a matching airflow direction. That is, all modules must have a front-to-back (F2B) airflow direction, or all modules must have a back-to-front (B2F) airflow direction. The airflow direction of PSUs and fan trays is indicated by labels on the modules.



Go to the chapter [“Power and Grounding”](#)

Figure 9: Connecting AC Power

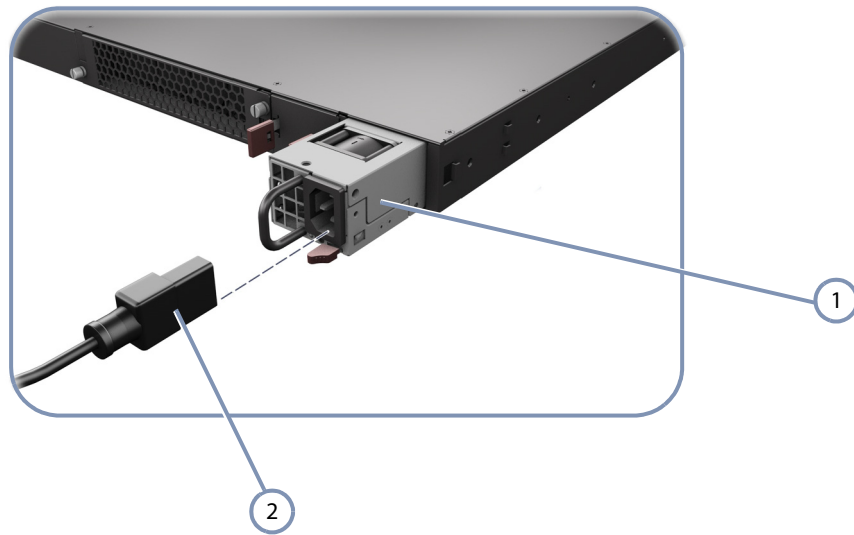

- 1 Install one or two universal AC power modules in the switch.
- 2 Connect an external AC power source to the modules.

Task 5 Verify Switch Operation

Verify basic switch operation by checking the system LEDs.

When operating normally, the PSU1/PSU2, Diag, and Fan LEDs should all be on green. If any of the LEDs are on amber, see [“Diagnosing LED Indicators” on page 58](#)

➔ Go to the section [“Understanding the System Status LEDs”](#)

Figure 10: System LEDs



- 1 System Status LEDs.

Task 6 Make Initial Configuration Changes

At this point you may need to make a few basic switch configuration changes before connecting to the network. It is suggested to connect to the switch console port to perform this task.

The serial port's configuration requirements are as follows: 115200 bps, 8 characters, no parity, one stop bit, 8 data bits, and no flow control.

You can log in to the command-line interface (CLI) using default settings: User "admin" with no password.

➔ Go to ["How to Connect to the Console Port"](#)

Figure 11: Console Port

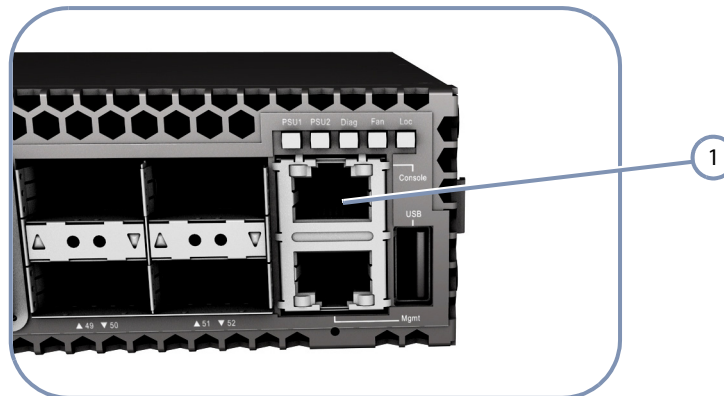

1 Console Port

For information on initial switch configuration:

➔ Refer to the *Administrator's Guide*.

Task 7 Install Transceivers and Connect Cables

Install SFP+ or QSFP+ transceivers and connect network cables to port interfaces:

- ◆ Connect DAC cables to the SFP+/QSFP+ slots. Or first install SFP+/QSFP+ transceivers and then connect fiber optic cabling to the transceiver ports.
- ◆ For the RJ-45 Management port, use 100-ohm Category 5, 5e or better cable for 1000BASE-T connections.

As connections are made, check the port status LEDs to be sure the links are valid.

➔ Go to the chapter “Port Connections”

Figure 12: Making a Connection to a QSFP+ Transceiver

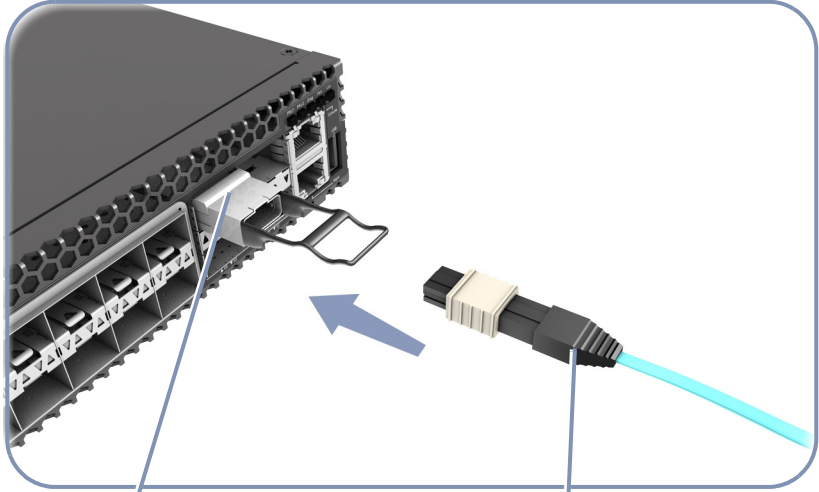

① Install QSFP+ transceivers.

② Connect fiber optic cabling to the ports.

3

Switch Chassis

The switch is designed to be installed in a standard 19-inch equipment rack.

Before continuing with switch installation, first review the general guidelines and switch cooling requirements in this chapter.

This chapter includes these sections:

- ◆ [“General Installation Guidelines” on page 25](#)
- ◆ [“How to Install the Switch in a Rack” on page 26](#)
- ◆ [“Switch Cooling Requirements” on page 28](#)

General Installation Guidelines

Be sure to follow the guidelines below when choosing a location.

- ◆ The installation location should:
 - be able to maintain its temperature within 0 to 40 °C (32 to 104 °F) and its humidity within 5% to 95%, non-condensing.
 - provide adequate space (approximately five centimeters or two inches) on all sides for proper air flow.
 - be accessible for installing, cabling and maintaining the device.
 - allow the status LEDs to be clearly visible.
- ◆ Make sure twisted-pair cable is always routed away from power lines, fluorescent lighting fixtures and other sources of electrical interference, such as radios and transmitters.
- ◆ Make sure the unit is connected to a separate grounded power outlet that is powered from an independent circuit breaker. As with any equipment, using a filter or surge suppressor is recommended. Verify that the external power requirements for the switch can be met as listed under [“Power Supply Modules” on page 31](#).

How to Install the Switch in a Rack

When rack mounting the switch, pay particular attention to the following factors:

- ◆ **Rack Types:** You can use any standard EIA 19-inch equipment rack with either two or four posts. The bracket hole pattern should be spaced 1U (1.75 in. or 4.45 cm) apart.
- ◆ **Rack Stability:** Whenever possible, secure the rack to the building ceiling or floor, particularly if you are located in a region where earthquakes are common.
- ◆ **Rack Planning:** When installing equipment in a rack, first plan how units can be best arranged. Try to always mount the heaviest equipment at the bottom of the rack.
- ◆ **Temperature:** Since the temperature within a rack assembly may be higher than the ambient room temperature, check that the rack-environment temperature is within the specified operating temperature range. See [“Switch Cooling Requirements” on page 28](#).
- ◆ **Mechanical Loading:** Do not place any equipment on top of a rack-mounted unit.
- ◆ **Circuit Overloading:** Be sure that the supply circuit to the rack assembly is not overloaded.
- ◆ **Grounding:** Rack-mounted equipment should be properly grounded.

Rack-Mounting Items Before you start to rack-mount the switch, be sure to have the following items available:

- ◆ Four mounting screws for each device you plan to install in a rack—these are not included. Be sure to use the rack mounting screws that are supplied with the rack.
- ◆ A screwdriver (Phillips or flathead, depending on the type of screws used).

Rack-Mount Procedure To rack mount the switch, follow these steps:



Caution: Installing the switch in a rack requires two people: One should position the switch in the rack, while the other secures it using the mounting screws.

1. Attach the brackets to the device using the screws provided in the Rack Mounting Kit.

Figure 13: Attaching the Brackets

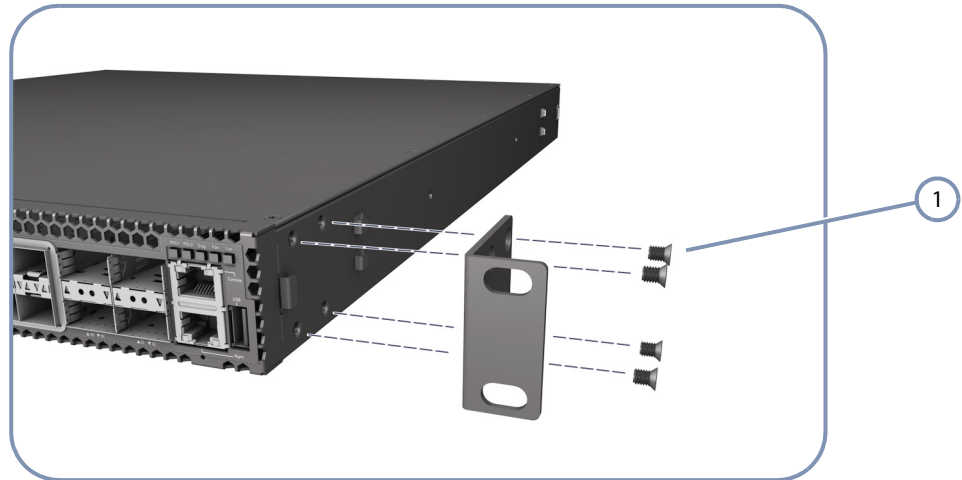

- 1 Use the screws provided in the Rack Mounting Kit.

2. Following your rack plan, mark the holes in the rack where the switch will be installed.
3. One person should lift the switch into the rack so that it is aligned with the marked holes.
4. The second person should secure the switch in the rack, using four rack-mounting screws (not provided).

Figure 14: Installing the Switch in a Rack

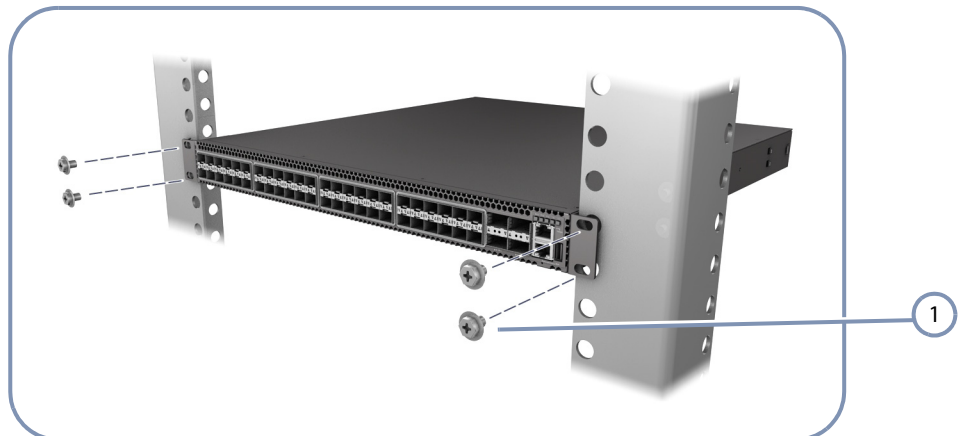

- 1 Use the rack mounting screws supplied with the rack.

5. If installing a single switch only, go to [“Power and Grounding” on page 31](#).
6. If installing multiple switches, repeat steps 1 to 4 to mount the switches following your rack plan.

Switch Cooling Requirements

Wherever the switch is located, be sure to pay close attention to switch cooling requirements. The location should be well ventilated and provide unrestricted air flow at the front, back, and sides of the switch. If the air flow is insufficient, it may cause the switch to overheat and possibly fail.

The switch includes a removable fan tray module located in the rear of the switch. The module options may have either a front-to-back (F2B) airflow direction or a back-to-front (B2F) airflow direction. The switch’s plug-in power supply modules also include a fan, which can be either F2B or B2F airflow direction. For proper switch cooling, all installed modules must have a matching airflow direction.

The following figure shows the airflow through the switch.

Figure 15: Switch Cooling

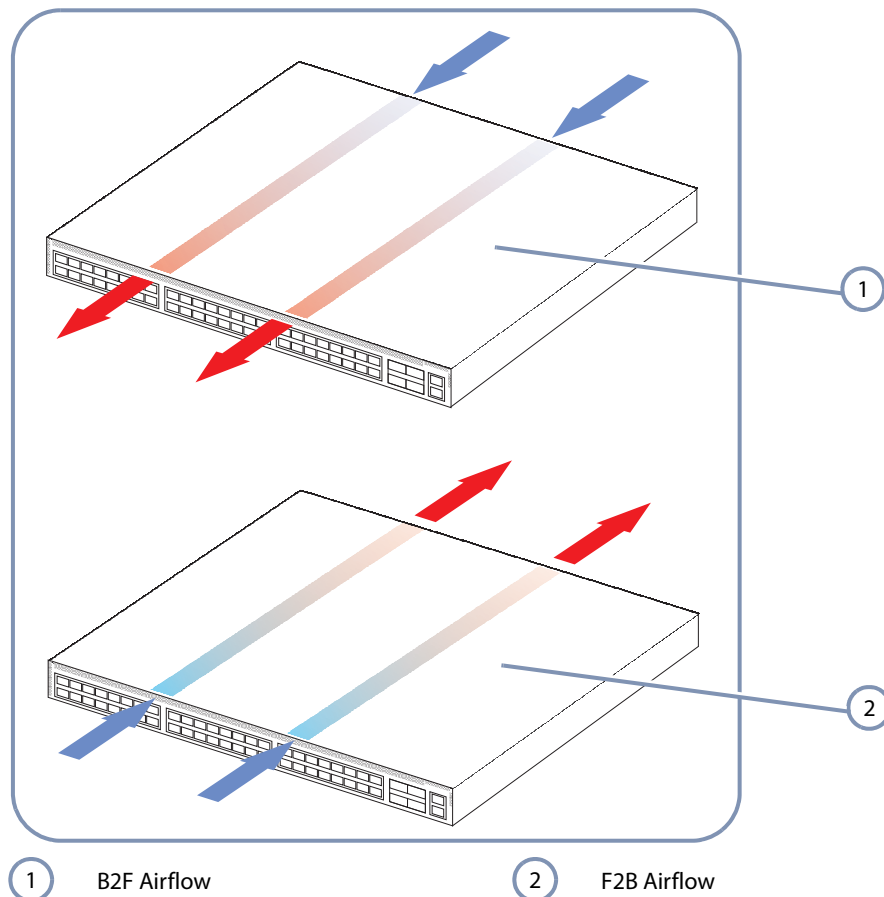

Rack Cooling When mounting the switch in an enclosed rack or cabinet, be sure to check the following guidelines to prevent overheating:

- ◆ Make sure that enough cool air can flow into the enclosure for the equipment it contains.
- ◆ Check that the rack or cabinet allows the hot air to exit the enclosure (normally from the top) without circulating back into equipment.
- ◆ If the enclosure has sides or doors with ventilation holes, make sure they are not blocked by cables or other obstructions.
- ◆ Route cables within the rack or cabinet to maximize the airflow.
- ◆ When possible, do not completely fill the rack or cabinet with equipment, allow some unused space within the enclosure for better airflow.

Fan Tray Module The fan tray module is an important part of the switch air cooling system. A fan tray module must be installed in the switch at all times. If a fan should fail, the whole fan tray module must be replaced as soon as possible.

You must install the fan tray module in the switch that matches the airflow direction of the installed power supply units. The available fan tray modules are listed below:

- ◆ AS5610S-FANTRAY (front-to-back airflow)
- ◆ AS5610SR-FANTRAY (back-to-front airflow)



Caution: The switch includes plug-in power supply and fan tray modules that are installed into its chassis. All installed modules must have a matching airflow direction. That is, all modules must have a front-to-back (F2B) airflow direction, or all modules must have a back-to-front (B2F) airflow direction. The airflow direction of PSUs and fan trays is indicated by labels on the modules.

The removable fan tray, located in the rear of the switch, includes four fixed fans and supports fan speed control. The fan speed is dynamically controlled as a function of temperature: the higher the internal temperature, the faster the speed of the fans. The fan tray module does not include LED indicators.

The following figure shows the fan tray removed from the switch.

Figure 16: Fan Tray

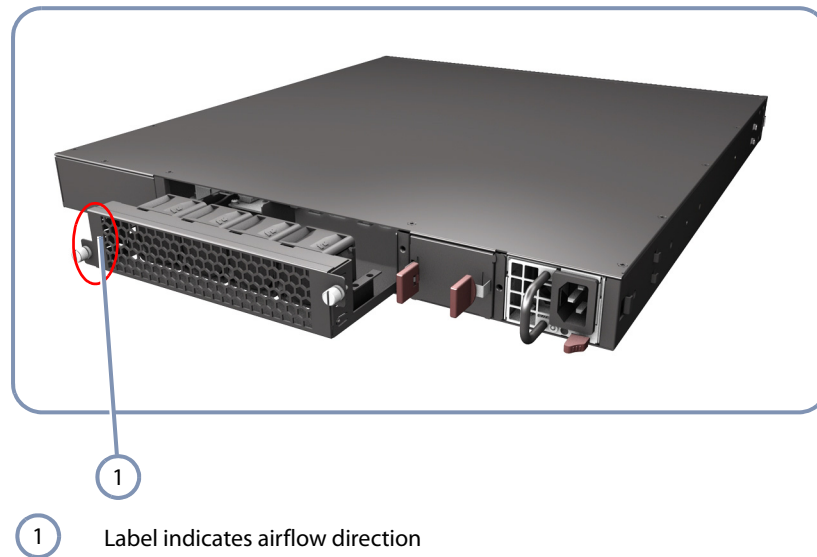

Table 2: Fan Tray Specifications

Item	Description
Power Consumption	12 VDC @ 2.8 A, 37 Watts maximum
Airflow	76.4 CFM minimum 90.4 CFM maximum
Dimensions	W x D x H: 207 x 94.25 x 40.4 mm (8.15 x 3.71 x 1.59 inches)

How to Replace a Fan Tray The switch system is shipped with a fan tray module installed. If a fan failure is detected (see [“Understanding the System Status LEDs” on page 52](#)), the module should be replaced immediately.

Follow this procedure to replace a fan tray:

1. Loosen the two retaining screws on the front panel of the fan tray.
2. Pull firmly on the screws until the fan tray is free.
3. Slide the fan tray out of the switch.
4. Insert the replacement fan tray into the slot and slide it slowly into the chassis.
5. Push firmly until the fan tray clicks into place. The fans should immediately start to operate.
6. Tighten the retaining screws to secure the fan tray in the chassis.

4

Power and Grounding

This chapter focuses on the switch power supplies, how to install them, and how to power-on the switch. Connecting the switch to ground is also covered.

This chapter includes these sections:

- ◆ “Power Supply Modules” on page 31
- ◆ “Grounding the Chassis” on page 33
- ◆ “How to Connect to AC Power” on page 34

Power Supply Modules

The switch supports hot-swappable power supply units (PSUs). You can install up to two PSUs with matching airflow direction in the switch. The PSUs operate in a load-sharing mode and provide 1+1 redundancy.



Note: 1+1 redundancy is a system where a switch power supply is backed up by another switch power supply in a load-sharing mode. If one power supply fails, the other power supply takes over the full load of the switch.

The switch provides two AC power supply module options, which are listed below:

- ◆ AS5610S-ACPWR (front-to-back airflow)
- ◆ AS5610SR-ACPWR (back-to-front airflow)



Caution: The switch includes plug-in power supply and fan tray modules that are installed into its chassis. All installed modules must have a matching airflow direction. That is, all modules must have a front-to-back (F2B) airflow direction, or all modules must have a back-to-front (B2F) airflow direction. The airflow direction of PSUs and fan trays is indicated by labels on the modules.

The AC Power Supply Modules require power from an external AC power supply that can provide 100 to 240 VAC, 50-60 Hz. A standard AC power socket is located on the rear panel of the PSU. The power socket is for the AC power cord.

Figure 17: AC Power Supply Module

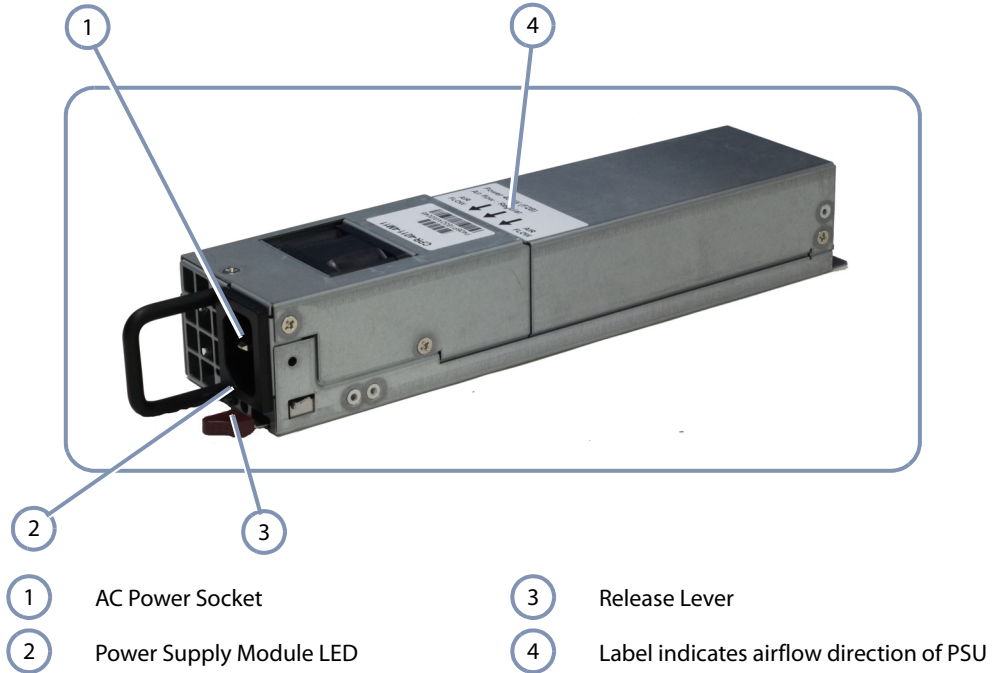

Table 3: AC Power Supply Module Specifications

Item	Description
AC Input	100-240 VAC, 50-60 Hz, 4-2 A
DC Output	5 VDC @ 3 A 12 VDC @ 33 A
Power Supply	100-240 VAC, 50-60 Hz, auto-sensing; hot pluggable 400 Watts@ 220V/110V per module
Power Consumption	165 Watts maximum
Maximum Current	4 A @ 100 VAC 2 A @ 240 VAC
Size	W x D x H: 54.5 x 220 x 40.25 mm (2.15 x 8.66 x 1.58 inches)

The PSU also includes an AC power status LED. This LED is described in the following table.

Figure 18: Power Supply Module LED

LED	Condition	Status
AC	Green	External AC power is connected to the module.
	Off	External power is not connected or has failed.

Grounding the Chassis

The switch chassis must be connected to ground to ensure proper operation and to meet electromagnetic interference (EMI) and safety requirements.

The rear panel of the switch chassis includes a single-screw grounding terminal. The surface area around this terminal is not painted in order to provide for a good connection. It must be connected to ground to ensure proper operation and to meet electromagnetic interference (EMI) and safety requirements.

Figure 19: Grounding Terminal

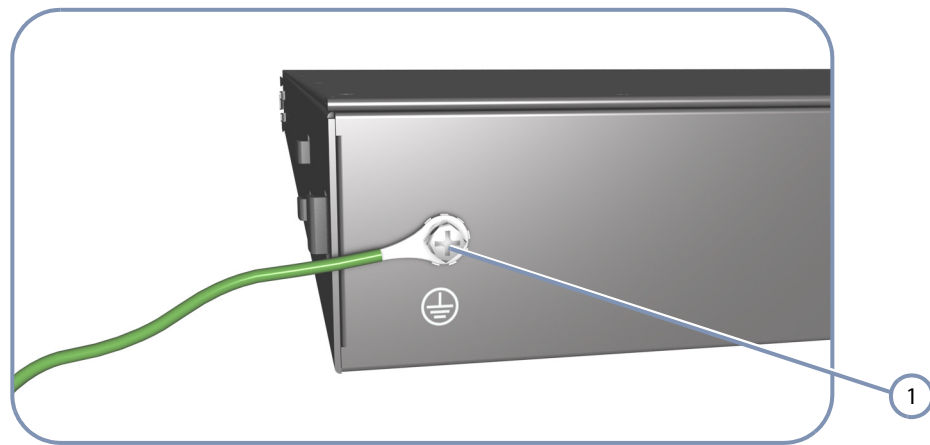

1 Grounding Terminal.

Before powering on the switch, ground the switch to earth as described below.

1. Ensure that the rack on which the switch is to be mounted is properly grounded and in compliance with ETSI ETS 300 253.
2. Ensure that there is a good electrical connection to the grounding point on the rack (no paint or isolating surface treatment).
3. Disconnect all power cables to the switch.
4. Attach a 6 AWG stranded copper wire to the grounding terminal on the switch.
5. Then attach the grounding wire to the ground point on the rack.



Caution: The earth connection must not be removed unless all supply connections have been disconnected.

How to Connect to AC Power

To supply AC power to the switch, first verify that the external AC power supply can provide 100 to 240 VAC, 50-60 Hz, 3 A minimum.

Note: For electrical safety purposes, please pay attention to the following warning notices, printed on the switch unit.



▲ 100 - 240VAC, 50 - 60Hz, 4 - 2A Per PS ▼

To connect the switch to a power source:

1. Install one or two AC PSU modules. Slide them into the PSU slots at the rear of the switch until they click into place. (Push the red release lever to remove a module from the switch.)

Figure 20: AC PSU and Power Socket

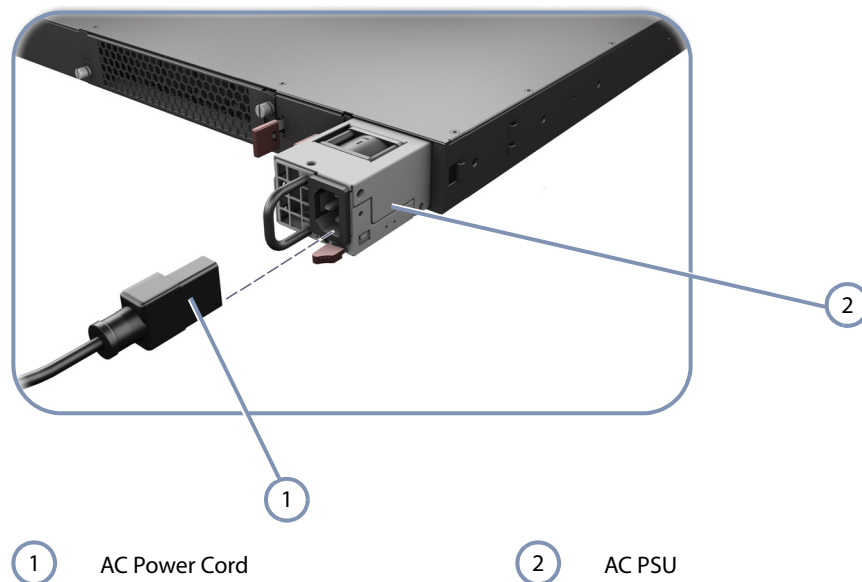

2. Plug the power cord into a grounded, 3-pin, AC power source.

Note: For international use, you may need to change the AC power cord. You must use a cord set that has been approved for the socket type in your country.

- 3.** Insert the plug on the other end of the power cord directly into the socket on the AC PSU.
- 4.** Check the LED indicators on the PSU and switch front panel as the unit is powered on to verify that power is being received. If not, recheck the PSU and power cord connections at the AC supply source and PSU.
- 5.** If you have installed a second PSU, repeat steps 2 to 4.

5

Port Connections

This chapter focuses on making connections to switch network interfaces, including how to install optional transceivers, and details on network cable specifications.

The switch features 48 SFP+ transceiver slots and four 40 Gigabit QSFP+ transceiver slots. The sections that follow describe these interfaces.



Note: The switch also has one 10/100/1000BASE-T port for dedicated management access. This port is described in [“How to Connect to the Management Port”](#) on [page 53](#).

This chapter includes these sections:

- ◆ [“Cable Labeling and Connection Records”](#) on page 38
- ◆ [“Understanding the Port Status LEDs”](#) on page 39
- ◆ [“How to Install an SFP/SFP+/QSFP+ Transceiver”](#) on page 40
- ◆ [“How to Connect to Twisted-Pair Copper Ports”](#) on page 41
- ◆ [“How to Connect to SFP/SFP+ Fiber Optic Ports”](#) on page 44
- ◆ [“How to Connect to QSFP+ Fiber Optic Ports”](#) on page 46
- ◆ [“DAC Connections”](#) on page 48

Cable Labeling and Connection Records

When planning a network installation, it is essential to label the opposing ends of cables and to record where each cable is connected. Doing so will enable you to easily locate inter-connected devices, isolate faults and change your topology without need for unnecessary time consumption.

To best manage the physical implementations of your network, follow these guidelines:

- ◆ Clearly label the opposing ends of each cable.
- ◆ Using your building's floor plans, draw a map of the location of all network-connected equipment. For each piece of equipment, identify the devices to which it is connected.
- ◆ Note the length of each cable and the maximum cable length supported by the switch ports.
- ◆ For ease of understanding, use a location-based key when assigning prefixes to your cable labeling.
- ◆ Use sequential numbers for cables that originate from the same equipment.
- ◆ Differentiate between racks by naming accordingly.
- ◆ Label each separate piece of equipment.
- ◆ Display a copy of your equipment map, including keys to all abbreviations at each equipment rack.

Understanding the Port Status LEDs

The switch includes LED indicators for each port to indicate link status and network activity. The port LEDs are shown below and described in the following table.

Figure 21: Port Status LEDs

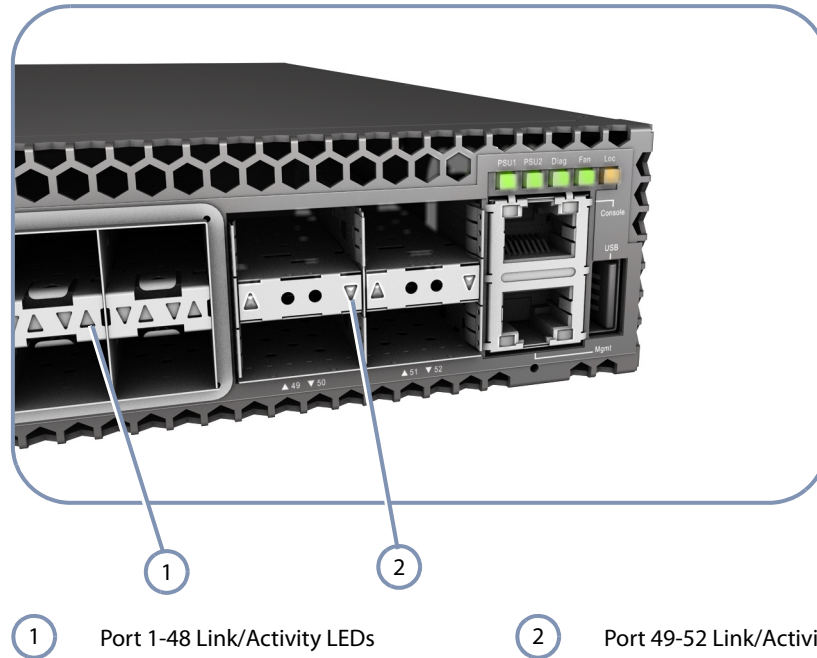

1 Port 1-48 Link/Activity LEDs

2 Port 49-52 Link/Activity LEDs

Figure 22: Port Status LEDs

LED	Condition	Status
10G SFP+ Ports (1-48)		
Link/Activity	On/Flashing Green	Port has a valid 10G link. Flashing indicates activity on the port.
	On/Flashing Amber	Port has a valid 1G link. Flashing indicates activity on the port.
	Off	The link is down.
40G QSFP+ Ports (49-52)		
Link/Activity	On Green	Port has a valid 40G link.
	Flashing Green	Flashing indicates activity on the port.
	Off	The link is down.

How to Install an SFP/SFP+/QSFP+ Transceiver

The switch provides slots for optional SFP, SFP+, and QSFP+ transceivers. The supported transceiver types are listed below:

- ◆ 40 Gbps Ethernet QSFP+ transceivers
 - 40GBASE-CR4
 - 40GBASE-SR4
- ◆ 10 Gbps Ethernet SFP+ transceivers
 - 10GBASE-CR
 - 10GBASE-SR
- ◆ 1000 Mbps Ethernet SFP transceivers
 - 1000BASE-SX
 - 1000BASE-LX



Note: SFP/SFP+/QSFP+ transceivers are hot-swappable. The switch does not need to be powered off before installing or removing a transceiver.

Note: SFP/SFP+/QSFP+ transceivers are not provided in the switch package.

To install an SFP/SFP+/QSFP+ transceiver, do the following:

1. Consider network and cabling requirements to select an appropriate transceiver type that is also compatible with the switch transceiver support.
2. If the SFP/SFP+/QSFP+ slot is covered with a rubber protective cap, remove the cap and keep it for later replacement.
3. Insert the transceiver with the optical connector facing outward and the slot connector facing down. Note that SFP/SFP+/QSFP+ transceivers are keyed so they can only be installed in the correct orientation.
4. Slide the transceiver into the slot until it clicks into place. If you do not immediately connect a cable to the port, use a rubber protective cap to keep the transceiver optics clean.

Figure 23: Inserting an SFP/SFP+/QSFP+ Transceiver into a Slot

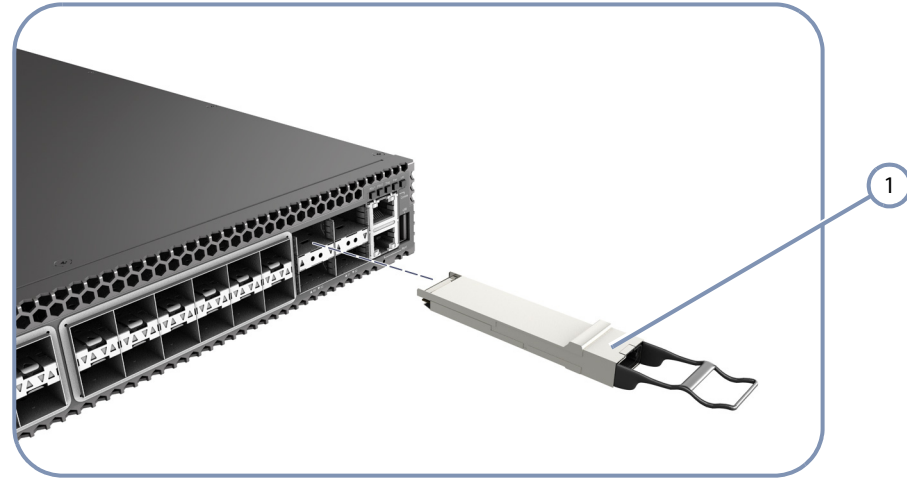

1 QSFP+ Transceiver



Note: To uninstall a transceiver: First disconnect the network cable, then release and pull the wire bail to remove the transceiver from the slot.

How to Connect to Twisted-Pair Copper Ports

The RJ-45 management port on the switch supports automatic MDI/MDI-X pinout configuration, so you can use standard straight-through twisted-pair cables to connect to any other network device (PCs, servers, switches, routers, or hubs).

The connection requires an unshielded twisted-pair (UTP) cable with RJ-45 connectors at both ends. Use Category 5, 5e or 6 cable for 1000BASE-T connections, Category 5 or better for 100BASE-TX connections, and Category 3 or better for 10BASE-T connections.

Table 4: Maximum Twisted-Pair Copper Cable Lengths

Cable Type	Maximum Cable Length	Connector
1000BASE-T		
Category 5, 5e, or 6 100-ohm UTP or STP	100 m (328 ft)	RJ-45
100BASE-TX		
Category 5 or better 100-ohm UTP or STP	100 m (328 ft)	RJ-45
10BASE-T		
Category 3 or better 100-ohm UTP	100 m (328 ft)	RJ-45

Copper Cabling Guidelines

To ensure proper operation when installing the switch into a network, make sure that the current cables are suitable for 10BASE-T, 100BASE-TX or 1000BASE-T operation. Check the following criteria against the current installation of your network:

- ◆ Cable type: Unshielded twisted pair (UTP) or shielded twisted pair (STP) cables with RJ-45 connectors; Category 3 or better for 10BASE-T, Category 5 or better for 100BASE-TX, and Category 5, 5e or 6 for 1000BASE-T.
- ◆ Protection from radio frequency interference emissions
- ◆ Electrical surge suppression
- ◆ Separation of electrical wires (switch related or other) and electromagnetic fields from data based network wiring
- ◆ Safe connections with no damaged cables, connectors or shields

10/100BASE-TX Pin Assignments

All 100BASE-TX RJ-45 ports support automatic MDI/MDI-X operation, so you can use straight-through or crossover cables for all network connections to PCs, switches, or hubs. In straight-through cable, pins 1, 2, 3, and 6, at one end of the cable, are connected straight through to pins 1, 2, 3, and 6 at the other end of the cable.

Figure 24: RJ-45 Connector

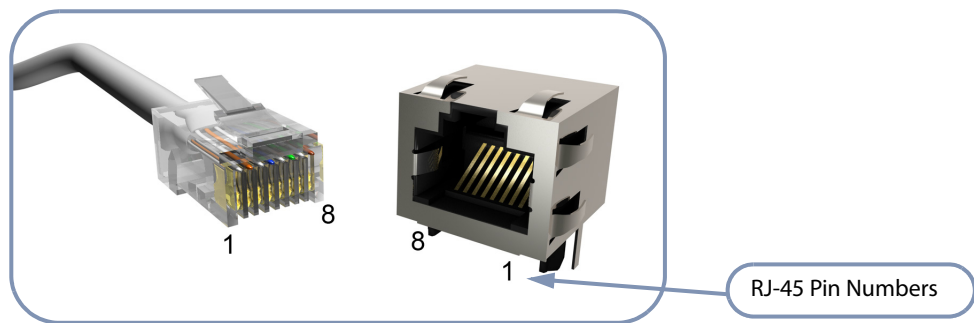

Table 5: 10/100BASE-TX MDI and MDI-X Port Pinouts

Pin	MDI Signal Name ^a	MDI-X Signal Name
1	Transmit Data plus (TD+)	Receive Data plus (RD+)
2	Transmit Data minus (TD-)	Receive Data minus (RD-)
3	Receive Data plus (RD+)	Transmit Data plus (TD+)
6	Receive Data minus (RD-)	Transmit Data minus (TD-)
4,5,7,8	Not used	Not used

a. The "+" and "-" signs represent the polarity of the wires that make up each wire pair.

1000BASE-T Pin Assignments All 1000BASE-T ports support automatic MDI/MDI-X operation, so you can use straight-through cables for all network connections to PCs, servers, or switches.

The table below shows the 1000BASE-T MDI and MDI-X port pinouts. These ports require that all four pairs of wires be connected. Note that for 1000BASE-T operation, all four pairs of wires are used for both transmit and receive.

Table 6: 1000BASE-T MDI and MDI-X Port Pinouts

Pin	MDI Signal Name	MDI-X Signal Name
1	Bi-directional Pair A Plus (BI_DA+)	Bi-directional Pair B Plus (BI_DB+)
2	Bi-directional Pair A Minus (BI_DA-)	Bi-directional Pair B Minus (BI_DB-)
3	Bi-directional Pair B Plus (BI_DB+)	Bi-directional Pair A Plus (BI_DA+)
4	Bi-directional Pair C Plus (BI_DC+)	Bi-directional Pair D Plus (BI_DD+)
5	Bi-directional Pair C Minus (BI_DC-)	Bi-directional Pair D Minus (BI_DD-)
6	Bi-directional Pair B Minus (BI_DB-)	Bi-directional Pair A Minus (BI_DA-)
7	Bi-directional Pair D Plus (BI_DD+)	Bi-directional Pair C Plus (BI_DC+)
8	Bi-directional Pair D Minus (BI_DD-)	Bi-directional Pair C Minus (BI_DC-)

1000BASE-T Cable Requirements

All Category 5 UTP cables that are used for 100BASE-TX connections should also work for 1000BASE-T, providing that all four wire pairs are connected. However, it is recommended that for all critical connections, or any new cable installations, Category 5e (enhanced Category 5) or Category 6 cable should be used. The Category 5e and 6 specifications include test parameters that are only recommendations for Category 5. Therefore, the first step in preparing existing Category 5 cabling for running 1000BASE-T is a simple test of the cable installation to be sure that it complies with the IEEE 802.3-2008 standards.

Connection Procedure The switch has one 10/100/1000BASE-T port for dedicated management access. Making a connection to this port is described in [“How to Connect to the Management Port” on page 53.](#)

How to Connect to SFP/SFP+ Fiber Optic Ports

The switch provides 48 slots for SFP/SFP+ fiber-optic transceivers. Note that all 10G SFP+ fiber optic ports operate at 10 Gbps full duplex. All 1000 Mbps SFP fiber optic ports operate at 1 Gbps full duplex.

Table 7: Maximum 10 Gigabit Ethernet Fiber Cable Lengths

Fiber Size	Fiber Bandwidth	Maximum Cable Length	Connector
10GBASE-SR			
62.5/125 micron multimode	160 MHz/km	2-26 m (7-85 ft.)	LC
62.5/125 micron multimode	200 MHz/km	2-33 m (7-108 ft.)	LC
50/125 micron multimode	400 MHz/km	2-66 m (7-216 ft.)	LC
50/125 micron multimode	500 MHz/km	2-82 m (7-269 ft.)	LC
50/125 micron multimode	2000 MHz/km	2-300 m (7-984 ft.)	LC

Table 8: Maximum Gigabit Ethernet Fiber Cable Lengths

Cable Type	Fiber Bandwidth	Maximum Cable Length	Connector
1000BASE-SX			
62.5/125 micron multimode	160 MHz/km	2-220 m (7-722 ft)	LC
	200 MHz/km	2-275 m (7-902 ft)	LC
50/125 micron multimode	400 MHz/km	2-500 m (7-1641 ft)	LC
	500 MHz/km	2-550 m (7-1805 ft)	LC
1000BASE-LX			
9/125 micron single-mode	N/A	2 m - 10 km (7 ft - 6.2 miles)	LC



Note: The length of fiber optic cable for a single switched link should not exceed the relevant standards specified in this section. However, power budget constraints should also be considered when calculating the maximum fiber optic cable length for a particular link.

Connection Procedure Follow these steps to connect cables to SFP/SFP+ transceiver ports.



Warning: This switch uses lasers to transmit signals over fiber optic cable. The lasers are compliant with the requirements of a Class 1 Laser Product and are inherently eye safe in normal operation. However, you should never look directly at a transmit port when it is powered on.

Warning: When selecting a fiber SFP/SFP+ device, considering safety, please make sure that it can function at a temperature that is not less than the recommended maximum operational temperature of the product. You must also use an approved Laser Class 1 SFP/SFP+ transceiver.

1. Remove and keep the fiber port's rubber cover. When not connected to a fiber cable, the rubber cover should be replaced to protect the optics.
2. Check that the fiber terminators are clean. You can clean the cable plugs by wiping them gently with a clean tissue or cotton ball moistened with a little ethanol. Dirty fiber terminators on fiber cables will impair the quality of the light transmitted through the cable and lead to degraded performance on the port.
3. Connect one end of the cable to the LC connector on one of the switch's SFP transceivers and the other end to the LC port on the other device. Since both LC connectors are keyed, the cable can only be attached in the correct orientation.

Figure 25: Making Connections to an SFP+ Transceiver

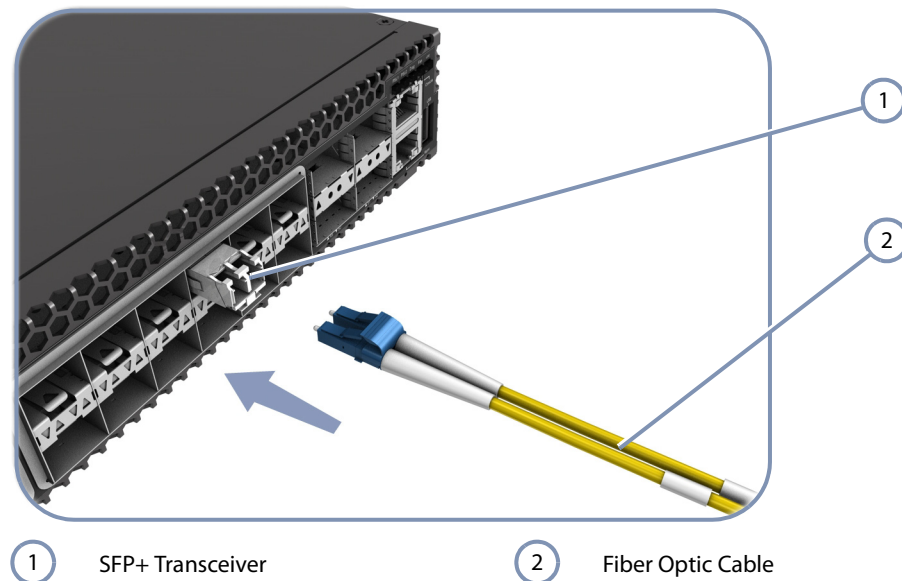

4. As a connection is made, check the Link LED on the switch corresponding to the port to be sure that the connection is valid.



Note: Be sure to secure cables properly and route them away from the switch without exceeding the minimum bending radius for fiber cables (typically a few inches). Use cable ties to bundle cables together and secure coiled loops of excess cable. Do not let cables hang free supporting their own weight or pull in any way that puts stress on the connectors.

How to Connect to QSFP+ Fiber Optic Ports

The switch includes four slots for 40 Gigabit Ethernet QSFP+ fiber-optic transceivers. Note that 40G fiber optic ports can provide either one 40 Gbps full-duplex link, four independent 10G fiber optic links. Connecting a 40G QSFP+ port to four 10G SFP+ ports requires the use of a breakout cable.

Table 9: Maximum 40 Gigabit Ethernet Fiber Cable Lengths

Fiber Size	Fiber Bandwidth	Maximum Cable Length	Connector
40GBASE-SR4			
62.5/125 micron multimode	160 MHz/km	2-26 m (7-85 ft.)	LC
62.5/125 micron multimode	200 MHz/km	2-33 m (7-108 ft.)	LC
50/125 micron multimode	400 MHz/km	2-66 m (7-216 ft.)	LC
50/125 micron multimode	500 MHz/km	2-82 m (7-269 ft.)	LC
50/125 micron multimode	2000 MHz/km	2-300 m (7-984 ft.)	LC



Note: The length of fiber optic cable for a single switched link should not exceed the relevant standards specified in this section. However, power budget constraints should also be considered when calculating the maximum fiber optic cable length for a particular link.

Connection Procedure Follow these steps to connect cables to QSFP+ transceiver ports.



Warning: This switch uses lasers to transmit signals over fiber optic cable. The lasers are compliant with the requirements of a Class 1 Laser Product and are inherently eye safe in normal operation. However, you should never look directly at a transmit port when it is powered on.

Warning: When selecting a fiber QSFP+ device, considering safety, please make sure that it can function at a temperature that is not less than the recommended maximum operational temperature of the product. You must also use an approved Laser Class 1 QSFP+ transceiver.

1. Remove and keep the port's protective cover. When not connected to a fiber cable, the cover should be replaced to protect the optics.
2. Check that the fiber terminators are clean. You can clean the cable plugs by wiping them gently with a clean tissue or cotton ball moistened with a little ethanol. Dirty fiber terminators on fiber cables will impair the quality of the light transmitted through the cable and lead to degraded performance on the port.

3. Connect one end of the cable to the QSFP+ port on the switch and the other end to the QSFP+ port on the other device. Since QSFP+ connectors are keyed, the cable can only be attached in the correct orientation.

Figure 26: Connecting to a QSFP+ Transceiver

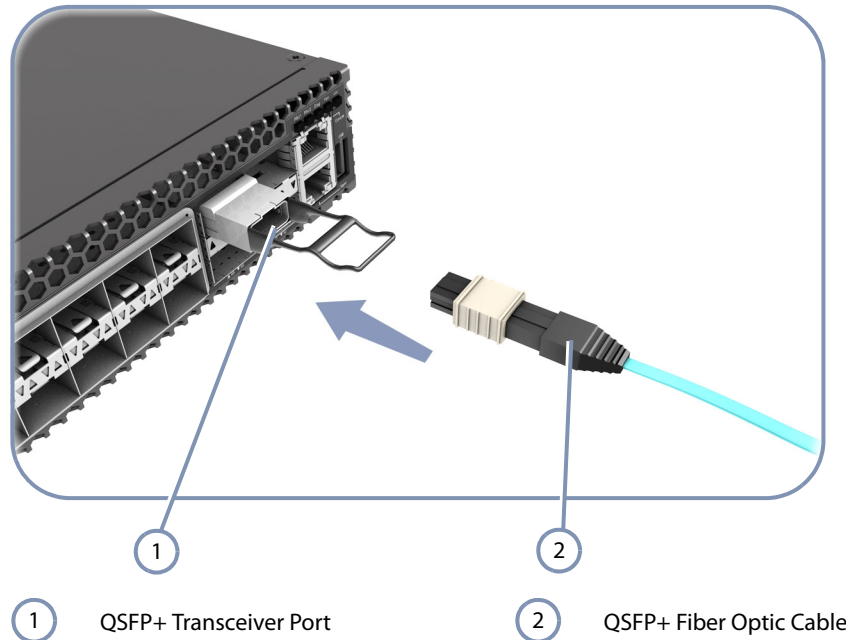

4. As a connection is made, check the Link LED on the switch to be sure that the connection is valid.

Note: Be sure to secure cables properly and route them away from the switch without exceeding the minimum bending radius for fiber cables (typically a few inches). Use cable ties to bundle cables together and secure coiled loops of excess cable. Do not let cables hang free supporting their own weight or pull in any way that puts stress on the connectors.

DAC Connections

Direct Attach Cable (DAC) is a method of connecting two SFP+/QSFP+ interfaces without using optics and fiber cable. A fixed length of twinax copper cable is terminated at each end with physically-compliant SFP+/QSFP+ transceivers that do not include all their normal electronic and optical components. The result is a low cost, low-latency, 10G/40G Ethernet solution for short distances, ideal for connections within the data center.

A 10G DAC connection is also known as twinax copper or 10GBASE-CR. DAC copper cables are available in pre-terminated lengths up to 7 m (22.9 ft).

For 40G DAC, or 40GBASE-CR4, copper cables are also available in pre-terminated lengths up to 7 m (22.9 ft).

Table 10: Maximum 10GBASE-CR 10 Gigabit Ethernet Cable Lengths

Cable Type	Cable Lengths	Connector
Pre-terminated Direct Attach Cable (DAC) — (twinax copper cable)	1 m (3.28 ft)	SFP+
	2 m (6.56 ft)	
	3 m (9.8 ft)	
	5 m (16.4 ft)	
	7 m (22.9 ft)	

Table 11: Maximum 40GBASE-CR4 40 Gigabit Ethernet Cable Lengths

Cable Type	Cable Lengths	Connector
Pre-terminated Direct Attach Cable (DAC) — (twinax copper cable)	1 m (3.28 ft)	QSFP+
	2 m (6.56 ft)	
	3 m (9.8 ft)	
	5 m (16.4 ft)	
	7 m (22.9 ft)	

Making DAC Connections

1. Plug the SFP+/QSFP+ transceiver connector on one end of a twinax copper cable segment into an SFP+/QSFP+ slot on the link device.

Figure 27: Making DAC Connections

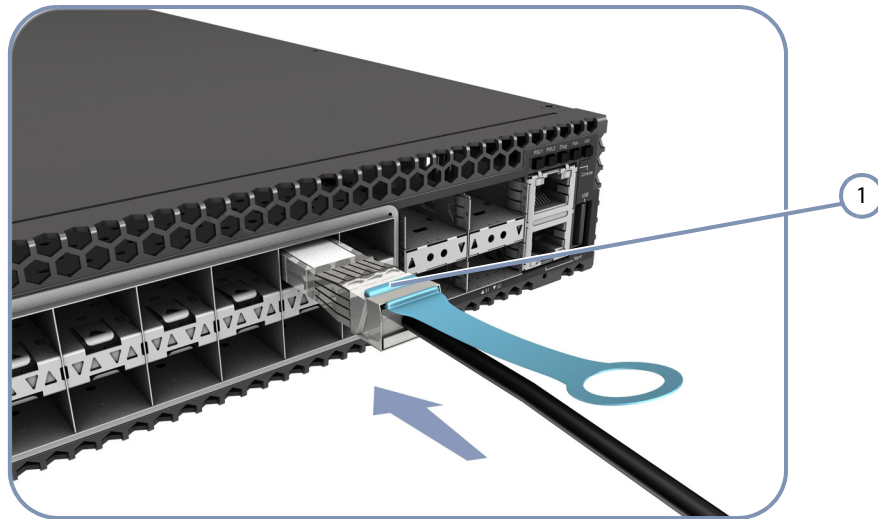

1 10G SFP+ DAC Cable

2. Plug the other end of the twinax cable into an SFP+/QSFP+ slot on the switch.
3. Check that the Link LED on the switch turns on green to indicate that the connection is valid.



Note: Connecting a 40G QSFP+ port to four 10G SFP+ ports requires the use of a breakout DAC cable.

6

Switch Management

The switch includes a management agent that allows you to configure or monitor the switch using its embedded management software. To manage the switch, you can make a direct connection to the console port (out-of-band), or you can manage it through a network connection (in-band) using Telnet, Secure Shell (SSH), a web browser, or SNMP-based network management software.

The switch's Management port (RJ-45) provides a dedicated management channel that operates outside of the data transport network. This makes it possible to re-configure or troubleshoot the switch over either a local or remote connection to the Management port when access through the data channel is not possible or deemed insecure.

For a detailed description of the switch's software features, refer to the *Administrator's Guide*.

This chapter includes these sections:

- ◆ ["Understanding the System Status LEDs" on page 52](#)
- ◆ ["How to Connect to the Management Port" on page 53](#)
- ◆ ["How to Connect to the Console Port" on page 54](#)
- ◆ ["How to Connect to the USB Port" on page 56](#)
- ◆ ["How to Reset the Switch" on page 57](#)

Understanding the System Status LEDs

The switch includes a display panel of key system LED indicators. The LEDs, which are located on the front panel, are shown below and described in the following table.

Figure 28: System LEDs



1 System Status LEDs.

Table 12: System Status LEDs

LED	Condition	Status
PSU1/PSU2	On Green	Power supply 1/2 is installed and operating normally.
	On Amber	The power supply has detected a fault.
	Off	The power supply unit is not installed.
Diag	On Green	The system diagnostic test has completed successfully.
	On Amber	The system self-diagnostic test has detected a fault.
Fan	On Green	Fans are operating normally.
	On Amber	A fan failure has been detected.
Loc	Flashing Amber	Activated through remote software to assist identification of the switch unit within a rack.

How to Connect to the Management Port

The 10/100/1000BASE-T port labeled “Mgmt” provides a dedicated management interface which is segregated from the data traffic crossing the other ports.

This port supports auto-negotiation, so the optimum transmission mode (half or full duplex) and data rate (10, 100, or 1000 Mbps) can be selected automatically, if this feature is also supported by the attached device.

Figure 29: Management Port

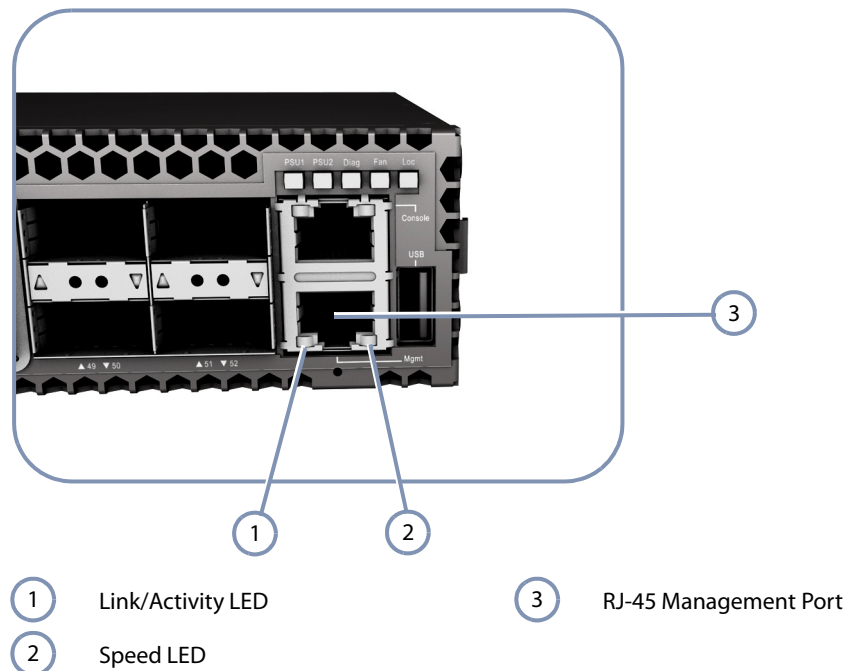

Table 13: RJ-45 Management Port Status LEDs

LED	Condition	Status
Link/Activity	On/Flashing Green	Port has established a valid network connection. Flashing indicates activity.
	Off	There is no valid link on the port.
Speed	On Amber	Valid 1000 Mbps link
	On Green	Valid 10/100 Mbps link

To connect to the management port, use Category 5 or better unshielded twisted-pair (UTP) cable with RJ-45 connectors at both ends. Make sure the twisted-pair cable does not exceed 100 meters (328 ft) in length. This port supports automatic MDI/MDI-X pinout configuration, so you can use standard straight-through cables to connect to any other network device.

Follow these steps to connect to the Management port:

1. Attach one end of a twisted-pair cable to an RJ-45 connector on a management network device (PC or another switch).
2. Attach the other end of the twisted-pair cable to the Management port on the switch.
3. As the connection is made, the Mgmt port LEDs (on the switch) will turn on to indicate that the connection is valid.

How to Connect to the Console Port

The RJ-45 Console port on the switch's front panel is used to connect to the switch for out-of-band console configuration. The console device can be a PC or workstation running a VT-100 terminal emulator, or a VT-100 terminal. An RJ-45-to-DB-9 cable is supplied with the switch for connecting to a PC's RS-232 serial DB-9 DTE (COM) port.



Note: To connect to notebooks or other PCs that do not have a DB-9 COM port, use a USB to male DB-9 adapter cable (not included with the switch).

Figure 30: Console Port

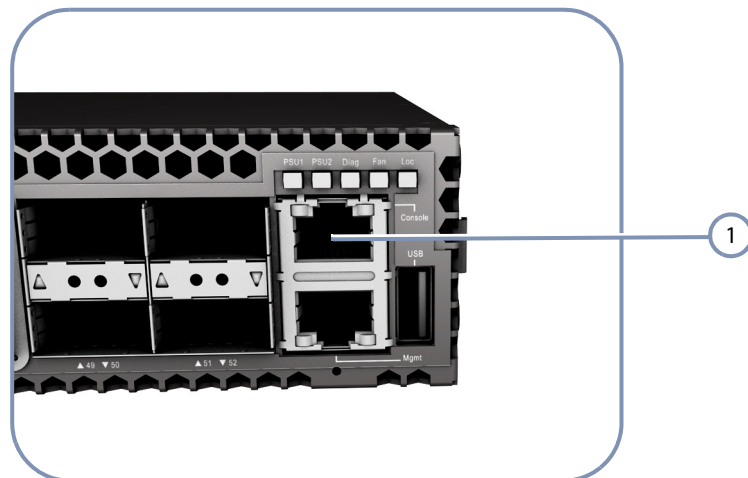

1 Console Port

The following table describes the pin assignments used in the RJ-45-to-DB-9 console cable.

Table 14: Console Cable Wiring

Switch's 8-Pin Console Port	Null Modem	PC's 9-Pin DTE Port
6 RXD (receive data)	<-----	3 TXD (transmit data)
3 TXD (transmit data)	----->	2 RXD (receive data)
5 SGND (signal ground)	-----	5 SGND (signal ground)

No other pins are used.

The serial port's configuration requirements are as follows:

- ◆ Default Baud rate—115200 bps
- ◆ Character Size—8 Characters
- ◆ Parity—None
- ◆ Stop bit—One
- ◆ Data bits—8
- ◆ Flow control—none

Figure 31: Console Port Connection

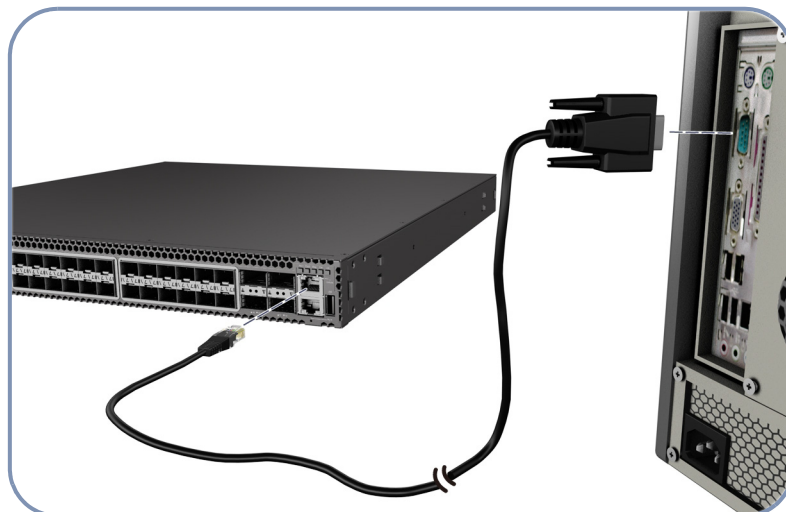

Follow these steps to connect to the Console port:

1. Attach the DB-9 end of the included RJ-45-to-DB-9 serial cable to a DB-9 COM port connector on a management PC.

2. Attach the RJ-45 end of the serial cable to the Console port on the switch.
3. Configure the PC's COM port required settings using VT-100 terminal emulator software (such as HyperTerminal) running on the management PC.
4. Log in to the command-line interface (CLI) using default settings:
 - User — admin
 - Password — *null* (there is no default password)

For a detailed description of connecting to the console and using the switch's command line interface (CLI), refer to the *Administrator's Guide*.

How to Connect to the USB Port

The USB port on the switch front panel is for transferring configuration files from a USB storage device to the switch's flash memory.

Figure 32: USB Port

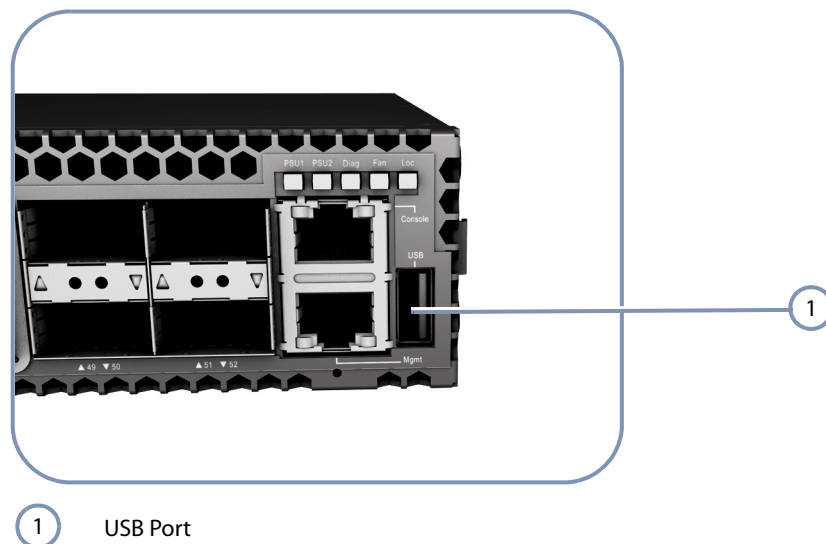

How to Reset the Switch

The Reset button on the switch can be used to restart the device and set the configuration back to factory default values.

Use a long thin object, such as the end of a paperclip, to press the Reset button. One push of the button restarts the system software using default values.

Figure 33: Reset Button

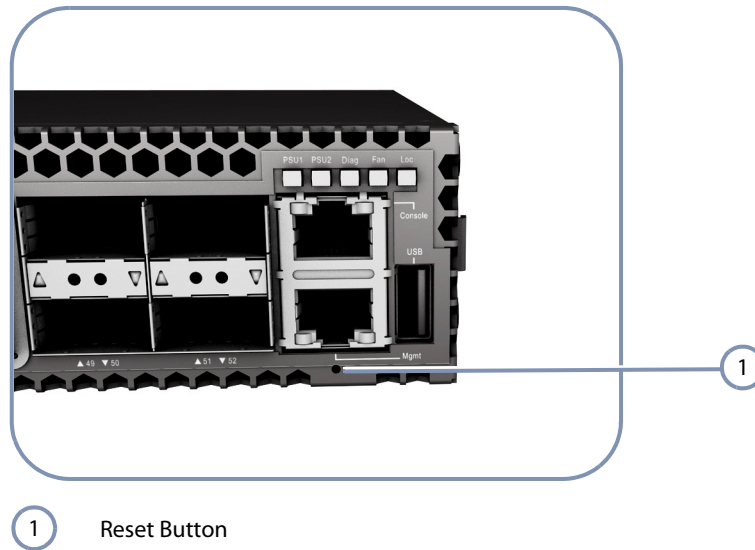

1 Reset Button



Troubleshooting

Diagnosing LED Indicators

Table 15: Troubleshooting Chart

Symptom	Action
PSU1/PSU2 LED is Off	<ul style="list-style-type: none">◆ Check connections between the PSU, the power cord and the wall outlet.◆ Contact your dealer for assistance.
PSU1/PSU2 LED is on Amber	<ul style="list-style-type: none">◆ Power cycle the PSU to try and clear the condition.◆ Replace the PSU.
Diag LED is on Amber	<ul style="list-style-type: none">◆ Power cycle the switch to try and clear the condition.◆ If the condition does not clear, contact your dealer for assistance.
Fan LED is on Amber	<ul style="list-style-type: none">◆ Check fans in the fan tray.◆ Replace the fan tray as soon as possible.
Link/Act LED is Off	<ul style="list-style-type: none">◆ Verify that the switch and attached device are powered on.◆ Be sure the cable is plugged into both the switch and corresponding device.◆ Verify that the proper cable type is used and its length does not exceed specified limits.◆ Check the attached device and cable connections for possible defects. Replace the defective cable if necessary.

System Self-Diagnostic Test Failure

If the Diag LED indicates a failure of the system power-on-self-test (POST), you can use a console connection to view the POST results. The POST results may indicate a failed component or help troubleshoot the problem. For more information on connecting to the console port and using the CLI, refer to the *Administrator's Guide*.

Note a POST failure normally indicates a serious hardware fault that cannot be rectified or worked around. If you encounter a POST failure, you should contact your dealer for assistance.

Power and Cooling Problems

If a power indicator does not turn on when the power cord is plugged in, you may have a problem with the power outlet, power cord, or PSU. However, if the switch powers off after running for a while, check for loose power connections, power losses or surges at the power outlet. If you still cannot isolate the problem, the PSU may be defective.

Installation

Verify that all system components have been properly installed. If one or more components appear to be malfunctioning (such as the power cord or network cabling), test them in an alternate environment where you are sure that all the other components are functioning properly.

In-Band Access

You can access the management agent in the switch through a connection to any port using Telnet, a web browser, or other network management software tools. However, you must first configure the switch with a valid IP address, subnet mask, and default gateway. If you have trouble establishing a link to the management agent, check to see if you have a valid network connection. Then verify that you entered the correct IP address. Also, be sure the switch port has not been disabled. If it has not been disabled, then check the network cabling that runs between your remote location and the switch.

Index

Numerics

10/100 PIN assignments 42
1000BASE-SX fiber cable Lengths 44
1000BASE-T PIN assignments 43
10GBASE fiber cable lengths 44, 46
10GBASE-LR fiber cable lengths 48

A

air flow requirements 25

B

brackets, attaching 27
buffer size 13

C

cable
 Ethernet cable compatibility 42
 labeling and connection records 38
 lengths 44, 46
cleaning fiber terminators 45, 46
console port
 pin assignments 53, 54
console port, pin assignments 54
contents of package 18
cord sets, international 34
Craft port 51

D

diagnosing LED indicators 58

E

electrical interference, avoiding 25
equipment checklist 18

F

fan tray 29

I

in-band access 59
indicators, LED 39, 52

installation

 power requirements 25
 site requirements 25
installation troubleshooting 59
introduction 10, 18

L

laser safety 44, 45, 46
LC port connections 44
LED indicators
 DIAG 52
 port 39
 power 32
 PWR 52
location requirements 25

M

management
 Craft port 51
 out-of-band 51
 web-based 51

O

out-of-band management 51

P

package contents 18
pin assignments
 console port 53, 54
power
 indicators 32
 modules 31
power and cooling problems 59

R

rear panel socket 31

S

screws for rack mounting 26
SFP
 transceiver connections 44

site selection 25
specifications
 environmental 13
status LEDs 39, 52
surge suppressor, using 25

W

web-based management 51



The Declaration of Conformity (DoC) can be obtained from www.edge-core.com -> support -> download -> declarations & certifications.